



**rohaus**  
TECHNIEKMACHT

rohaus.com

# Extreme Steam Iron

Instruction

RI810K

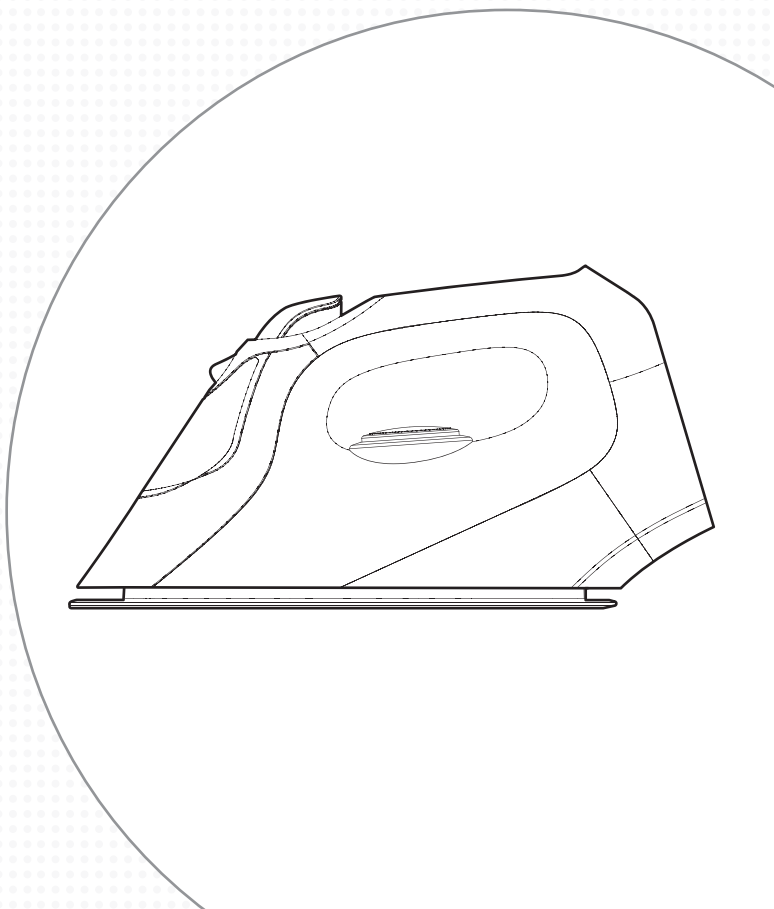

CE





# Contents

Introduction	3
Rohaus Safety Precautions	4
Features of your Rohaus Extreme Steam Iron	6
Using your Steam Iron	8
Auto shut-off feature	10
Care and Cleaning	11
Ironing Tips and Tricks	12
Ironing chart	13

Please read these instructions and retain for further reference.





# Introduction

Congratulations on the purchase of your Rohaus Extreme Steam Iron.

Combining Dutch technology, European engineering, 21st century design and professional product specification, for us, an outstanding appliance is not just a delight to use, it should inspire pride in ownership. Working in harmony with you, a natural expression of your style and skills, tough and powerful and yet with a balanced precision, every appliance we put our name to amplifies technique and enhances life.

We call this: Living Engineering.

The Rohaus Extreme Steam Iron is designed with premium durable scratch resistant Rodilium soleplate that together with extreme shot of steam focused in the tip of the soleplate provide a superior glide for effortless and quick ironing.





# Rohaus Safety Precautions

- Do not leave a hot iron within reach of children. If they come into contact with a hot iron it could lead to serious burns.
- Iron only on an ironing board.
- An iron takes approximately 30 minutes to cool down. Allow the iron to cool completely before storing.
- Do not wind the cord around the soleplate while the iron is still hot.

**Rohaus is very safety conscious when designing and manufacturing consumer products, but it is essential that the product user also exercise care when using an electrical appliance. Listed below are precautions which are essential for the safe use of an electrical appliance:**

- Read carefully and save all the instructions provided with an appliance.
- Always turn the power off at the power outlet before you insert or remove a plug. Remove by grasping the plug - do not pull on the cord.
- Turn the power off and remove the plug when the appliance is not in use and before cleaning.
- Do not use your appliance with an extension cord unless this cord has been checked and tested by a qualified technician or service person.
- Always use your appliance from a power outlet of the voltage (A.C. only) marked on the appliance.
- This appliance is not intended for use by persons (including children) with reduced physical, sensory or mental capabilities, or lack of experience and knowledge, unless they have been given supervision or instruction concerning use of the appliance by a person responsible for their safety.
- Children should be supervised to ensure that they do not play with the appliance.
- The temperature of accessible surfaces may be high when the appliance is operating.
- Never leave an appliance unattended while in use.
- Do not use an appliance for any purpose other than its intended use.
- Do not place an appliance on or near a hot gas flame, electric element or on a heated oven.
- Do not place on top of any other appliance.
- Do not let the power cord of an appliance hang over the edge of a table or bench top or touch any hot surface.



- Do not operate any electrical appliance with a damaged cord or after the appliance has been damaged in any manner. If damage is suspected, return the appliance to the nearest Rohaus Appointed Service Centre for examination, repair or adjustment.
- For additional protection, Rohaus recommend the use of a residual current device (RCD) with a tripping current not exceeding 30mA in the electrical circuit supplying power to your appliances.
- Do not immerse the appliance in water or any other liquid unless recommended.
- Appliances are not intended to be operated by means of an external timer or separate remote control system.
- This appliance is intended to be used in household and similar applications such as: staff kitchen areas in shops, offices and other working environments; farm houses; by clients in hotels, motels and other residential type environments; bed and breakfast type environments.

**If you have any concerns regarding the performance and use of your appliance, please visit [www.rohaus.com](http://www.rohaus.com) or contact the Rohaus Consumer Service Line. Ensure the above safety precautions are understood**



# Features Of Your Rohaus Steam Iron

## Powerful shot of steam

Pressing the shot of steam button instantly produces a powerful shot of steam to remove stubborn wrinkles.

## Vertical shot of steam

Pressing the shot of steam button with the iron in an upright position produces a vertical shot of steam, which is ideal for steaming curtains and suits, and removing creases from delicate fabrics.

## Fine spray mist

Pressing the spray button provides a fine mist spray to dampen hard-to-iron fabrics.

## Easy-fill water inlet

Holds 300ml of water for continual high steam performance without having to refill the tank regularly.

## Drip-stop steam system

The drip-stop steam system automatically stops water flowing to the steam chamber should the temperature fall too low to generate steam. This prevents dripping, even at low temperatures.

## Full length button groove

For ironing around buttons.

## 2400 watts for fast heat up

Provides faster initial heat up and rapid heat recovery during ironing. The 2400W element helps to maintain your selected temperature, and provides superior shot of steam output.

## Rodilium non-scratch soleplate

Rodilium is a durable, scratch resistant surface that provides a superior glide and prevents rucking. Exclusive to Rohaus, this premium soleplate features 172 steam holes to maximise steam distribution.

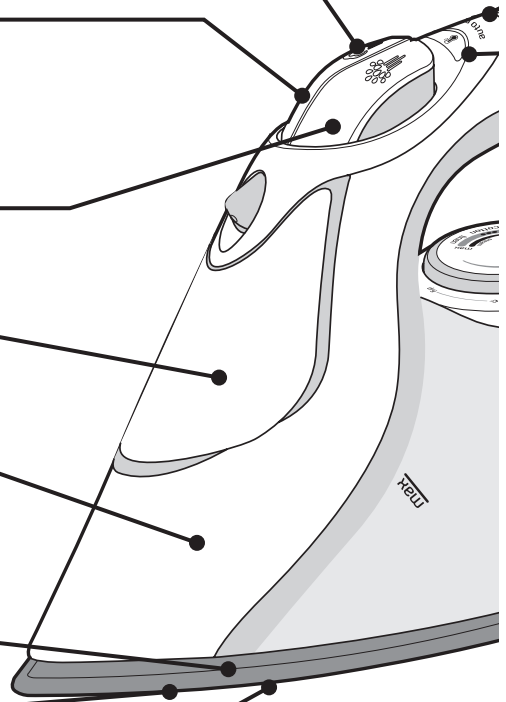



### Safety auto-off

The iron automatically switches itself off if left in the ironing position (horizontal) for 30 seconds, or in the heel rest position (vertical) for 15 minutes. (For more information on the safety auto off feature see page 7).

### Power light

Illuminates to indicate that the iron is connected to the power outlet and the power is turned on.

### Thermostat light

Illuminates to indicate that the iron is heating and goes out when it has reached the temperature selected on the temperature dial. The thermostat light cycles on and off during ironing as the iron maintains the selected temperature.

### Stable heel rest

Extra large heel rest keeps the iron stable on the ironing board.

### Cord wrap

The built-in cord wrap facility allows you to wind the cord around the heel for neat and tidy storage of the cord when the iron is not in use.

### Concentric steam and temperature dials

The steam and temperature dials are positioned together for easy adjustment.

### Variable steam dial

Allows you to select the desired steam output for each garment. Alternatively, select the DRY setting to iron without steam.

### Temperature dial

Allows you to select the desired temperature for each garment. The adjustable temperature dial also indicates the amount of steam recommended for use on each temperature setting.

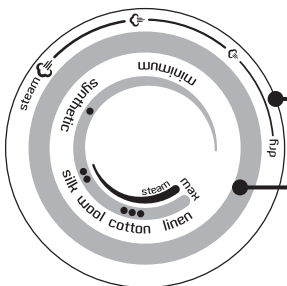
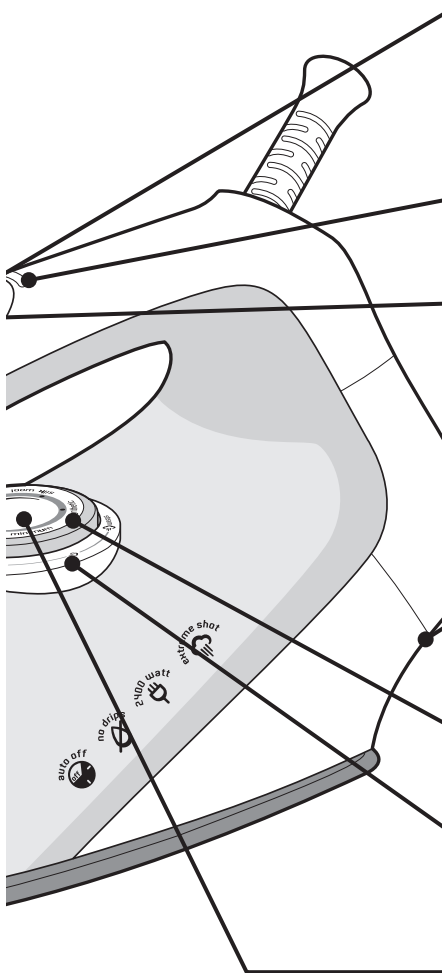

Steam Dial

Temperature Dial





# Using Your Rohaus Steam Iron

## Before first use

Remove any adhesive stickers, plastic covers or cardboard sleeves from the soleplate.

Ensure that all adhesive is removed by rubbing the soleplate with a cloth dampened with methylated spirits.

Fill the water tank and empty the water. This will rinse out any foreign particles remaining in the water tank from the manufacturing process.

---

**NOTE:** When turned on for the first time, your new iron may give off vapours for up to 10 minutes. This is due to the initial heating of the materials used. It is safe, not detrimental to the performance of the iron, and will not reoccur.

---

## Filling the iron with water

Before filling the iron with water ensure the power is turned off and the plug is removed from the power outlet. The iron can be filled with water while it is hot.

Place the iron on its heel and open the water inlet cover.

Slowly pour water into the water inlet until the maximum water level is reached. Do not exceed the maximum water level indicator.

Push the water inlet cover firmly to close.

---

**NOTE:** The special soleplate design allows you to use tap water with your Steam iron without affecting the steam performance. However in very hard water areas, Rohaus recommends the use of distilled water, or water which has been demineralised.

---

Use as a direct replacement for tap water to prolong the life of your iron.

Do not fill the iron with fabric conditioner, starches or any other solution as these will damage the steam mechanism. Do not use contaminated water.

## Using your iron

**1.** Insert the plug into a 220-240 volt power outlet and turn the power on. The power ON light (positioned on top of the handle) will illuminate to indicate that the iron is switched on and heating.

**2.** Turn the temperature dial to the desired setting by aligning the setting on the dial with the temperature indicator. The thermostat light will illuminate to indicate that the iron is heating to the selected temperature. When the thermostat light goes out the iron has reached the selected temperature and is ready to use.

---

**NOTE:** When the temperature dial is changed from a high setting to a lower temperature setting during ironing, the thermostat light will go out immediately. This indicates that the iron is cooling to the selected temperature.

---

To ensure that the iron has reached the selected temperature and is not too hot, wait until the thermostat light comes on again and then goes out before ironing.

## Steam ironing

Follow steps 1 and 2 above.

---

**NOTE:** When steam ironing, ensure that the temperature dial is set to any temperature within the steam band, and that the tank is at least  $\frac{1}{4}$  full of water.

---

**3.** Turn the steam dial to the desired steam setting.

For best results, select the steam setting that corresponds to the selected temperature, as indicated on the temperature dial.







### Dry ironing

Follow steps 1 and 2 above.

**3.** Select DRY on the steam dial.

This will cut off the steam flow if there is water in the tank.

### Using the shot of steam

The shot of steam can be used when dry or steam ironing, when the temperature dial is set to any temperature within the steam band or above the two dot (••) setting.

1. Ensure the tank is at least  $\frac{1}{4}$  full of water.
2. Select the desired temperature and wait until the thermostat light goes out.
3. Press the shot of steam button several times with the iron on the soleplate to prime the pump.

---

**Note:** If the tank has run dry, it may be necessary to re-prime the pump after filling the iron with water.

---

### Using the spray mist

The spray mist can be used whether dry or steam ironing to pre-dampen hard to iron fabrics.

1. Ensure the tank is at least  $\frac{1}{4}$  full of water.
2. Press the spray button during ironing to release a fine mist from the spray nozzle.

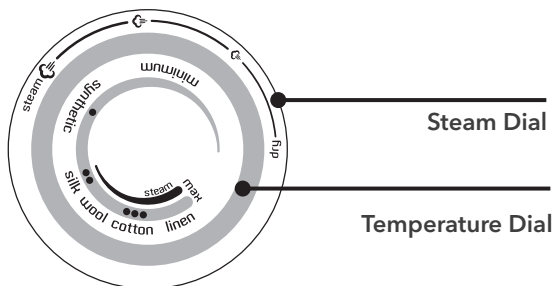

# The Safety Auto-Off Feature

The safety auto-off mechanism automatically turns the iron off if you forget.

The iron will automatically shut off if left on the heel rest (vertical) for 15 minutes, or in the ironing position (horizontal) for 30 seconds, without being moved. (See figure 2).

The thermostat and power lights on the handle will flash and a warning beep will sound to let you know that you have left the iron unattended.

Power to the iron's heating element will be cut.

Once the iron is moved the power will reconnect. Allow the iron to heat until the thermostat light goes out, and continue ironing as normal.

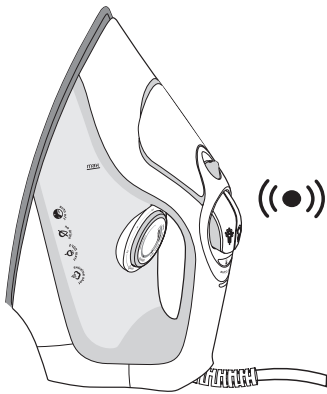

**15 Minutes**

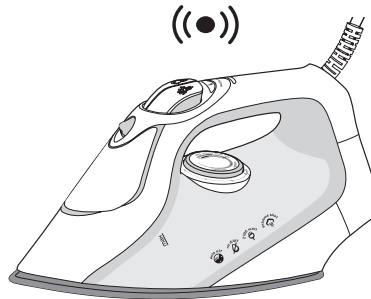

**30 Seconds**



# Care And Cleaning

## After each use

1. Turn the power off and remove the plug from the power outlet.
2. Allow the iron to cool before winding the cord around the built-in cord wrap.

## Storage

Always store the iron on its heel rest.

Do not store the iron with the soleplate facing down, or in the carton.

## Cleaning

To clean the exterior of your iron, wipe over with a damp soft cloth and wipe dry.

**Caution: Do not use harsh abrasives, chemical cleaners or solvents to clean the exterior of your iron as these will damage the surface.**

## Cleaning the steam holes

To remove build up from the steam holes which may affect steam performance, use a cotton wool tip moistened in methylated spirits.

## Cleaning the Rodilium soleplate

Wipe with a soft damp cloth and wipe dry.





# Ironing Tips And Tricks

## Tip # 1 - Iron shirts like a pro

Start with the collar, working from the outer edges into the middle. Iron the shoulder next, followed by the cuffs and sleeves. Place the collar at the narrow end of the board so that one front panel of the shirt is extended flat. Iron the front panel from shoulder to shirt tail. Rotate to iron the back of the shirt. Rotate and complete the remaining front panel.

## Tip # 2 - Tips for T-shirts

Straighten seams on t-shirts before hanging out to dry. To avoid damage to printed graphics and logos turn the t-shirt inside out and iron the reverse side of the print. Never iron areas of your t-shirt where perspiration marks are visible as the heat of the iron will permanently fix the stain.

## Tip # 3 - Hung out to dry

When washing is complete, remove shirts from the machine immediately, shake them out and hang them on coat hangers to air dry - this will keep wrinkles to a minimum.

## Tip # 4 - Selecting the right temperature

If you are unsure of the correct setting for a particular garment, test a small area such as a seam or inside hem before ironing a visible area. Start with a low temperature and slowly increase the heat to find the best setting.

## Tip # 5 - Don't be afraid to iron silk

Don't be afraid to iron silk. Although delicate in appearance, silk is the strongest and most resilient of all natural fibres. To achieve the best results, set to a low cotton setting and use regular shots of steam. Always use a pressing cloth to avoid shine marks.

## Tip # 6 - Ironing the seam

Always press seams in the same direction they were made. When a garment is produced, the fibres will naturally settle in the direction they were initially pressed, so it's best not to iron against the grain.

## Tip # 7 - Sort types of fabric

Sort articles to be ironed according to the type of fabric. This will reduce the need to adjust the temperature constantly. Start with articles requiring lower temperatures and work your way through to items requiring higher settings.

## Tip # 8 - Summer frocks and frills

Steam is the key when ironing delicate summer fabrics such as muslin, cotton and linen. Don't press down with the iron, simply hover above the garment and steam it using a vertical shot of steam. Ruffling, netting, tulle or intricate hand detailing is also best ironed using this method.

## Tip # 9 - Pressing your winter woollies

Steam is crucial when pressing your winter woollies. Woollen garments can be hung and steamed using the vertical shot of steam feature. After steaming, brush the garment with your hand to plump up woollen fibres. If ironing the garment flat it is best to use a pressing cloth. Don't be afraid to apply pressure - steam and hold.

## Tip # 10 - Table settings to impress

To avoid unwanted creases always iron your table cloth after taking it out of the cupboard. A dinner party is a special occasion, so treat the table cloth as you would your own outfit. For best results, lay towels across your table and iron the table cloth over the towels. This will save you time and ensure a beautifully presented table setting.



# Ironing Chart

Fabric	Temp setting Ironing	Ironing recommendation
Acrylic	MINIMUM Min to •	Dry iron on reverse side of fabric
Acetate	MINIMUM Min to •	Dry iron on reverse side of fabric while still damp
Nylon	MINIMUM Min to •	Iron on reverse side of fabric
Polyester	SYNTHETIC •	Iron on reverse side of fabric
Rayon	SYNTHETIC •	Iron on reverse side of fabric
Viscose	SYNTHETIC •	Mainly dry iron. Steam can be used under manufacturer's instructions
Silk	SILK ••	Iron on reverse side of fabric. Use an ironing cloth to prevent shine marks and use regular shots of steam
Cotton Blends	WOOL ••	Check label and follow manufacturer's instructions. Use setting for the fibre requiring the lowest setting
Wool	WOOL ••	Steam iron on reverse side of fabric or use an ironing cloth. Brush gently to raise the fibres
Wool Blends	WOOL ••	Steam iron on reverse side of fabric or use an ironing cloth. Brush gently to raise the fibres
Corduroy	COTTON •••	Steam iron on reverse side of fabric or use an ironing cloth. Brush gently to raise the fibres
Cotton	COTTON •••	Steam iron while still damp or use spray to dampen. Use medium to high steam
Linen	LINEN ••• to Max	Iron on reverse side of fabric or use an ironing cloth to prevent shine marks, especially with dark colours. Iron while still damp or use spray to dampen. Use medium to high steam
Denim	MAXIMUM ••• to Max	Iron while still damp or use spray to dampen. Use maximum steam